



CAT 298

Classic Advanced Tweeter

Ø 104mm, 8Ω



Features:

- * 104mm aluminum face plate
- * Large diameter voice coil
- * Replaceable dome / coil assembly
- * Ferro fluid cooled
- * High power handling
- * Sturdy gold plated input tags

SPECIFICATIONS

General Data		
Overall Dimensions	DxH	104mm(4.09")x30mm(1.18")
Nominal Power Handling (DIN)	P	80W
Transient Power 10ms		1000W
Sensitivity 2.83V/1M		89dB SPL
Frequency Response		See graph
Dome Material		Acuflex™ hand coated soft dome
Net Weight	Kg	0.59
Electrical Data		
Nominal Impedance	Z	8Ω
DC Resistance	Re	5.2Ω
Voice Coil Inductance @ 1KHz	LBM	0.05mH
Voice Coil and Magnet Parameters		
Voice Coil Diameter	DIA	28mm
Voice Coil Height		2.5mm
HE Magnetic Gap Height	HE	2.5mm
Max. Linear Excursion	X	
Voice Coil Former		Aluminum
Voice Coil Wire		Copper
Number Of Layers		2
Magnet System Type		Ferrite
B Flux Density	B	1.45 T
BL Product	BXL	3.3 N.A
T-S Parameters		
Suspension Compliance	Cms	
Mechanical Q Factor	Qms	
Electrical Q Factor	Qes	
Total Q Factor	Qts	
Mechanical Resistance	Rms	
Moving Mass	Mms	0.5 g
Eq. Cas Air Load (liters)	VAS	
Resonant Frequency	Fs	900 Hz
Effective Piston Area	SD	6.0 cm ²

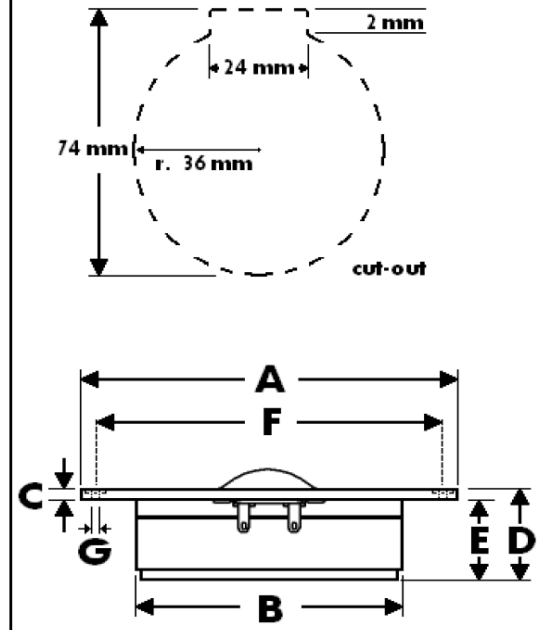

- A - Overall diameter 104mm
- B - Magnet/Chamber diameter 72mm
- C - Flange thickness 3mm
- D - Overall height 30mm
- E - Magnet/Chamber depth 27mm
- F - Mounting holes location diameter 94mm
- G - 3 Mounting holes, at 120° interval, inner hole diameter Ø 3.7mm, pocket h 1mm, Ø 7mm

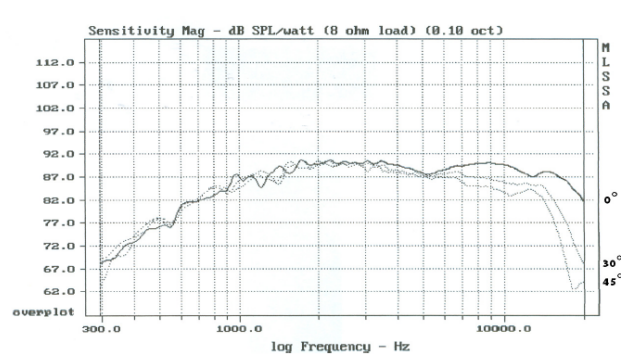
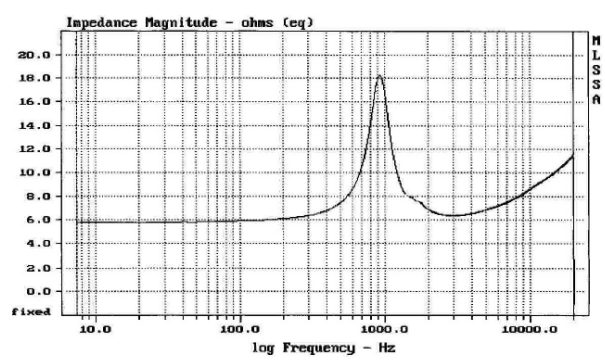

Measured on IEC baffle using Bruel & Kjaer 3144 model microphone.
 Morel operate policy of continuous product design improvement, consequently specifications are subject to alteration without prior notice.